



Overview

KEMET's A770 Surface Mount Solid Polymer Aluminum Capacitors offer longer life and greater stability across a wide range of temperatures. This highly conductive solid polymer electrolyte eliminates the risk of drying out and, due to its low leakage current properties, is suitable for on-board applications where electronics can be often in an off-mode. Low leakage current prevents a fast battery discharge. Able to withstand high ripple currents during normal operation. The A770 series is AEC-Q200 qualified and ideally suited for automotive and industrial applications. Anti-Vibration version is available for 10 mm diameter. If CV/Size is not available please [contact your local Sales Representative for more information.](#)

Applications

Typical applications include long life LED drivers, professional power amplifiers, industrial power supplies, DC/DC converters, voltage regulators, and decoupling. This series is used for automotive powertrain.

Benefits

- Low Leakage Current: $0.03 \times CV$
- High temperature: 125°C/2,000 hours
- Low impedance
- High vibration resistance up to 30 g
- Surface mount form factor
- RoHS compliant
- Halogen-free

Standard



Anti-Vibration



Part Number System

A	770	MS	107	M	1J	LA	S	027
Capacitor Class	Series	Size Code	Capacitance Code (pF)	Tolerance	Rated Voltage (VDC)	Packaging	Electrical Parameters	ESR
A = Aluminum	Surface Mount Solid Polymer Aluminum Capacitors 125°C 2,000 hours Low Leakage Current	See Dimension Table	First two digits represent significant figures for capacitance values. Last digit specifies the number of zeros to be added.	M = ±20%	16 = 1C 20 = 1D 25 = 1E 35 = 1V 40 = 1G 50 = 1H	LA = Tape & Reel	S = Automotive AEC-Q200 V = Automotive + Anti-Vibration	Last 3 digits represent significant figures for ESR values. (mΩ)

Ordering Options Table

Packaging Type	Packaging Code
Standard Packaging Options	
Tape & Reel	LA
Contact KEMET for other Lead and Packaging options	

Dimensions – Millimeters

Standard

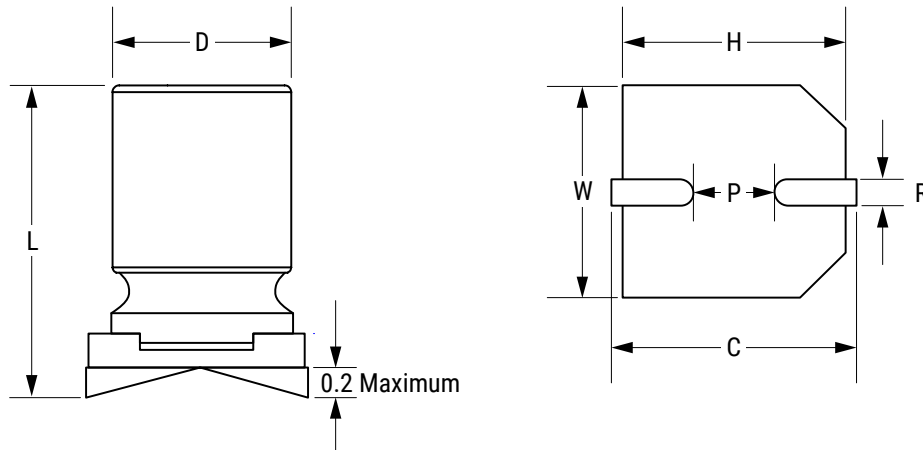

Anti-Vibration

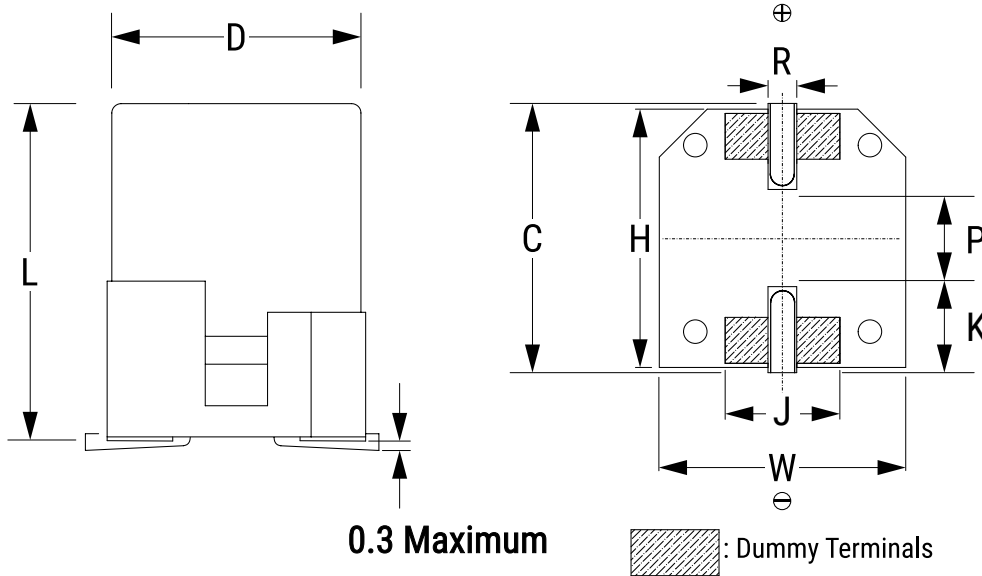

Size Code	D		L		W		H		C		R	P	J	K
	Nominal	Tolerance	Nominal	Tolerance	Nominal	Tolerance	Nominal	Tolerance	Nominal	Tolerance	Range	Nominal	Nominal	Nominal
KE	8	±0.5	6.7	±0.3	8.3	±0.2	8.3	±0.2	9	±0.2	0.8 – 1.1	3.1	-	-
KS	8	±0.5	12.2	±0.3	8.3	±0.2	8.3	±0.2	9	±0.2	0.8 – 1.1	3.2	-	-
MS	10	±0.5	12.2	±0.5	10.3	±0.2	10.3	±0.2	11	±0.2	0.8 – 1.1	4.6	-	-
MS (Anti-Vibration)	10	±0.5	12.4	±0.5	10.3	±0.2	10.8	±0.2	11	±0.2	0.7 – 1.1	4.6	4.4	3.2

Environmental Compliance



All Part Numbers in this datasheet are Reach and RoHS compliant, and Halogen-Free.

As an environmentally conscious company, KEMET is working continuously with improvements concerning the environmental effects of both our capacitors and their production. In Europe (RoHS Directive) and in some other geographical areas like China, legislation has been put in place to prevent the use of some hazardous materials, such as lead (Pb), in electronic equipment. All products in this catalog are produced to help our customers' obligations to guarantee their products and fulfill these legislative requirements. The only material of concern in our products has been lead (Pb), which has been removed from all designs to fulfill the requirement of containing less than 0.1% of lead in any homogeneous material. KEMET will closely follow any changes in legislation worldwide and make any necessary changes in its products, whenever needed.

Some customer segments such as medical, military and automotive electronics may still require the use of lead in electrode coatings. To clarify the situation and distinguish products from each other, a special symbol is used on the packaging labels for RoHS compatible capacitors.

Due to customer requirements, there may appear additional markings such as LF = Lead-free or LFW = Lead-free wires on the label.

Performance Characteristics

Item	Performance Characteristics
Capacitance Range	22 – 1,000 μ F
Rated Voltage	16 – 63 VDC
Operating Temperature	-55°C to +125°C
Capacitance Tolerance	\pm 20% at 120 Hz/20°C
Life Test	2,000 hours (see conditions in Test Method & Performance)
Leakage Current	$I = 0.03 CV$
C = Rated capacitance (μ F), V = Rated voltage (VDC), Voltage applied for 2 minutes at 20°C.	

Compensation Factor of Ripple Current (RC) vs. Frequency

Frequency	120 Hz $\leq f < 1$ kHz	1 kHz $\leq f < 10$ kHz	10 kHz $\leq f < 100$ kHz	100 kHz $\leq f < 500$ kHz
Coefficient	0.05	0.30	0.70	1.00

Test Method & Performance

Conditions	Load Life Test	Shelf Life Test
Temperature	125°C	125°C
Test Duration	2,000 hours	168 hours
Ripple Current	No ripple current applied	No ripple current applied
Voltage	The sum of DC voltage and the peak AC voltage must not exceed the rated voltage of the capacitor	No voltage applied
Performance	The following specifications will be satisfied when the capacitor is restored to 20°C.	
Capacitance Change	Within ±20% of the initial value	
Dissipation Factor	Does not exceed 150% of the specified value	
ESR	Does not exceed 150% of the specified value	
Leakage Current	Does not exceed specified value	
Damp Heat	The following specifications will be satisfied when the capacitor is restored to 20°C after application of rated voltage for 1,000 hours at 60°C, 90%~95% RH.	
Capacitance Change	Within ±20% of the initial value	
Dissipation Factor	Does not exceed 150% of the specified value	
ESR	Does not exceed 150% of the specified value	
Leakage Current	Does not exceed specified value	
Surge Voltage (Rated Voltage x 1.15(V))	The following specifications will be satisfied when the capacitor is subjected to 1,000 cycles, each consisting of charge with the surge voltages specified at 105°C for 30 seconds through a protective resistor (Rc = 1 kΩ) and discharge for 5 minutes, 30 seconds.	
Capacitance Change	Within ±20% of the initial value	
Dissipation Factor	Does not exceed 150% of the specified value	
ESR	Does not exceed 150% of the specified value	
Leakage Current	Does not exceed specified value	
Resistance to Soldering Heat	Measurement for solder temperature profile at capacitor top and terminal.	
Capacitance Change	Within ±10% of the initial value	
Dissipation Factor	Does not exceed 130% of the specified value	
ESR	Does not exceed 130% of the specified value	
Leakage Current	Does not exceed specified value	

Test Method & Performance – Anti-Vibration Version

Anti-Vibration Version	
Vibration Test Specifications	1.5 mm displacement amplitude or 30 g maximum acceleration. Vibration applied for three 4-hour sessions at 10 – 2,000 Hz (capacitor on PCB).
Capacitance Change	Within $\pm 20\%$ of the initial value
Dissipation Factor	Does not exceed 150% of the specified value
ESR	Does not exceed 150% of the specified value
Leakage Current	Does not exceed specified value

Shelf Life & Re-Ageing

Shelf Life

Solderability is 12 months after manufacturing date.

The capacitance, ESR and impedance of a capacitor will not change significantly after extended storage periods, however the leakage current will slowly increase.

- This series should not be stored in high temperatures or where there is a high level of humidity.
- The suitable storage condition is +5 to +35°C and less than 75% in relative humidity.
- Do not store in damp conditions such as water, saltwater spray or oil spray.
- Do not store in an environment of hazardous gas (hydrogen sulphide, sulphurous acid gas, nitrous acid, chlorine gas, ammonium, etc.)
- Do not store under exposure to ozone, ultraviolet rays or radiation.

If a capacitor has been stored for more than 12 months under these conditions and it shows increased leakage current, then a treatment by voltage application is recommended.

Note: The JEDEC-J-STD-020 standard does not apply.

Floor Life

The Capacitor should be soldered within 4 weeks after removal from sealed bag. Reseal the unused capacitors into plastic bags. All parts manufactured from week 1 of year 2022 are packed in sealed plastic bags.

Re-age Procedure

Apply the rated DC voltage to the capacitor at 125°C for a period of 120 minutes through a 1 k Ω series resistor.

Table 1 – Ratings & Part Number Reference

Rated Voltage	Surge Voltage	Rated Capacitance	ESR	Ripple Current	Leakage Current	Case Size	KEMET Part Number		Case Size
(VDC)	(VDC)	120 Hz 20°C (µF)	100 kHz 20°C (mΩ)	100 kHz 125°C (mA)	20°C 2 min (µA)	D x L (mm)	() Represents Part Number Options	Anti-Vibration Version	D x L (mm) Anti-Vibration
16	18.40	470	17	2,500	225.6	8×12.2	A770KS477M1CLAS017		
16	18.40	560	17	2,500	268.8	8×12.2	A770KS567M1CLAS017		
16	18.40	1,000	15	2,700	480.0	10×12.2	A770MS108M1CLAS015	A770MS108M1CLAV015	10×12.4
20	23.00	180	29	1,600	108.0	8×6.7	A770KE187M1DLAS029		
20	23.00	220	29	1,600	132.0	8×6.7	A770KE227M1DLAS029		
20	23.00	390	17	2,400	234.0	8×12.2	A770KS397M1DLAS017		
20	23.00	680	15	2,600	408.0	10×12.2	A770MS687M1DLAS015	A770MS687M1DLAV015	10×12.4
25	28.75	150	29	1,600	112.5	8×6.7	A770KE157M1ELAS029		
25	28.75	180	29	1,600	135.0	8×6.7	A770KE187M1ELAS029		
25	28.75	330	19	2,325	247.5	8×12.2	A770KS337M1ELAS019		
25	28.75	390	19	2,325	292.5	8×12.2	A770KS397M1ELAS019		
25	28.75	470	17	2,500	352.5	10×12.2	A770MS477M1ELAS017	A770MS477M1ELAV017	10×12.4
25	28.75	560	17	2,500	420.0	10×12.2	A770MS567M1ELAS017	A770MS567M1ELAV017	10×12.4
35	40.25	82	36	1,400	86.1	8×6.7	A770KE826M1VLAS036		
35	40.25	100	36	1,400	105.0	8×6.7	A770KE107M1VLAS036		
35	40.25	180	24	2,000	189.0	8×12.2	A770KS187M1VLAS024		
35	40.25	220	24	2,000	231.0	8×12.2	A770KS227M1VLAS024		
35	40.25	270	22	2,200	283.5	10×12.2	A770MS277M1VLAS022	A770MS277M1VLAV022	10×12.4
35	40.25	330	22	2,200	346.5	10×12.2	A770MS337M1VLAS022	A770MS337M1VLAV022	10×12.4
40	46.00	68	38	1,350	81.6	8×6.7	A770KE686M1GLAS038		
40	46.00	82	38	1,350	98.4	8×6.7	A770KE826M1GLAS038		
40	46.00	150	25	1,950	180.0	8×12.2	A770KS157M1GLAS025		
40	46.00	220	22	2,200	264.0	10×12.2	A770MS227M1GLAS022	A770MS227M1GLAV022	10×12.4
40	46.00	270	22	2,200	324.0	10×12.2	A770MS277M1GLAS022	A770MS277M1GLAV022	10×12.4
50	57.50	33	42	1,300	49.5	8×6.7	A770KE336M1HLAS042		
50	57.50	39	42	1,300	58.5	8×6.7	A770KE396M1HLAS042		
50	57.50	82	20	1,900	123.0	8×12.2	A770KS826M1HLAS020		
50	57.50	100	24	2,150	150.0	10×12.2	A770MS107M1HLAS024		
50	57.50	100	30	1,900	150.0	8×12.2	A770KS107M1HLAS030		
50	57.50	120	24	2,150	180.0	10×12.2	A770MS127M1HLAS024	A770MS127M1HLAV024	10×12.4
50	57.50	150	24	2,150	225.0	10×12.2	A770MS157M1HLAS024	A770MS157M1HLAV024	10×12.4
63	72.45	22	54	1,175	41.6	8×6.7	A770KE226M1JLAS054		
63	72.45	27	54	1,175	51.0	8×6.7	A770KE276M1JLAS054		
63	72.45	47	31	1,800	88.8	8×12.2	A770KS476M1JLAS031		
63	72.45	56	31	1,800	105.8	8×12.2	A770KS566M1JLAS031		
63	72.45	82	27	2,000	155.0	10×12.2	A770MS826M1JLAS027	A770MS826M1JLAV027	10×12.4
63	72.45	100	27	2,000	189.0	10×12.2	A770MS107M1JLAS027	A770MS107M1JLAV027	10×12.4
(VDC)	(VDC)	120 Hz 20°C (µF)	100 kHz 20°C (mΩ)	100 kHz 125°C (mA)	20°C 2 min (µA)	D x L (mm)	() Represents Part Number Options	Anti-Vibration Version	D x L (mm) Anti-Vibration
Rated Voltage	Surge Voltage	Rated Capacitance	ESR	Ripple Current	Leakage Current	Case Size	KEMET Part Number		Case Size

Landing Pad – Millimeters

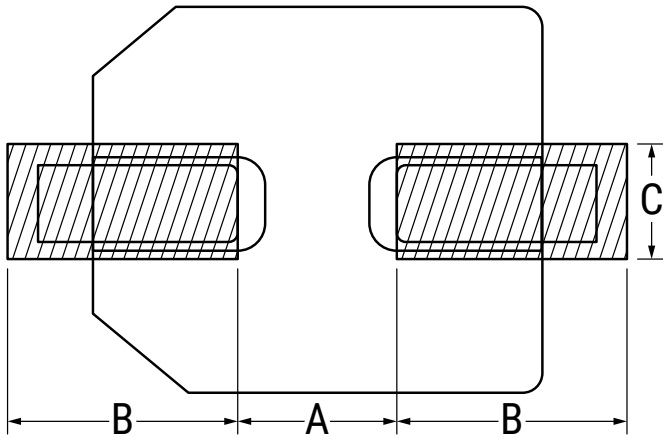

Diameter	A	B	C
8	3.1	4.2	2.2
10	4.5	4.4	2.2
10 (Anti-Vibration)	4.5	4.4	4.6

Marking

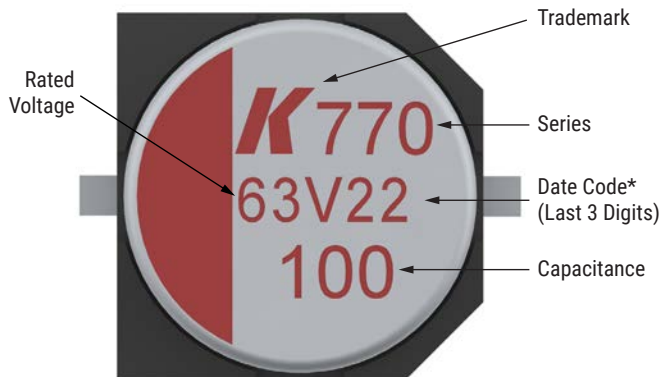

Date Code*	
1 st Digits = Rated Voltage	
Letter = Year Code	S = 2019
Final Digits = Week of the Year	01 = 1 st week of the Year to 52 = 52 nd week of the Year
Year Code	
S	2019
T	2020
U	2021
V	2022
W	2023
X	2024
Y	2025
Z	2026

Construction

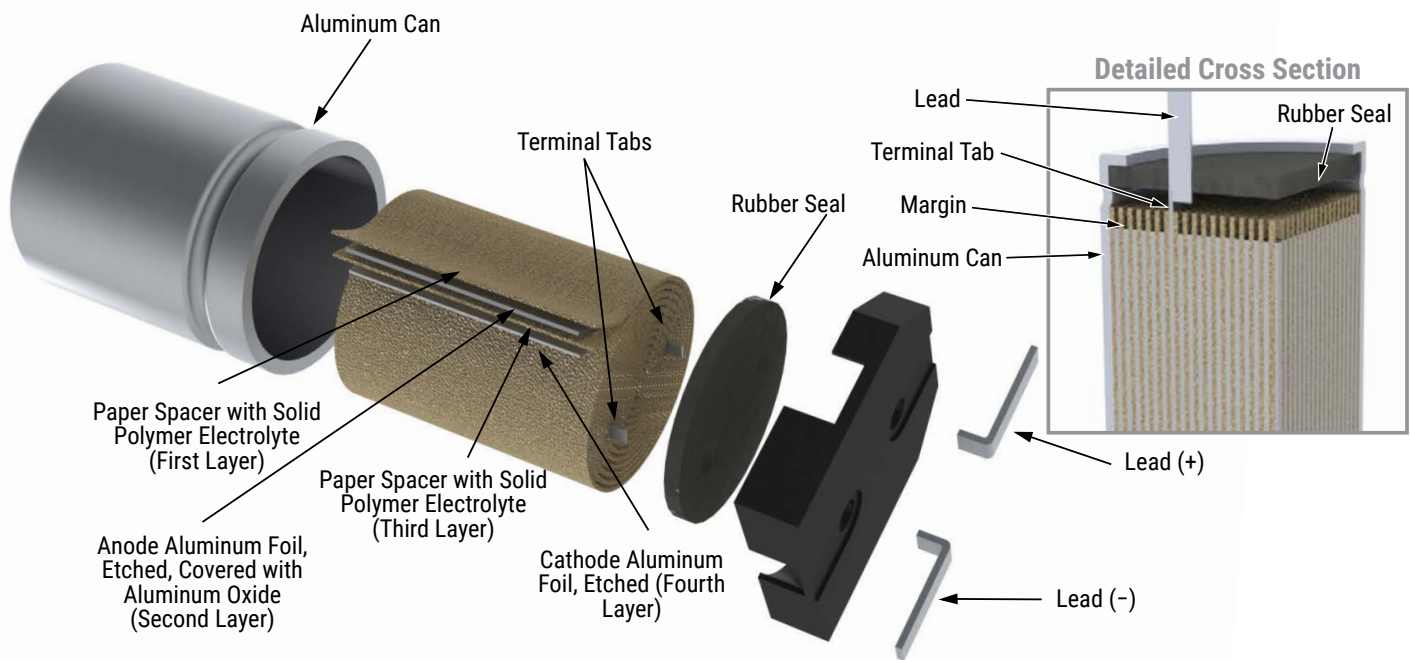

Re-Flow Soldering

The soldering conditions should be within the specified conditions below:

- Do not dip the capacitors body into the melted solder.
- Flux should only be applied to the capacitors terminals.
- Vapor heat transfer systems are not recommended. The system should be thermal, such as infra-red radiation or hot blast.
- Observe the soldering conditions as shown below.
- Do not exceed these limits and avoid repeated reflowing.

Time Period	Preheat t_s	t_L	t_d	t_p	Reflow Number
Temperature (°C)	150 – 180	≥ 217	≥ 230	260 250	1 1 or 2
Time (seconds)	60 - 120	≤ 50	≤ 40	≤ 5	-

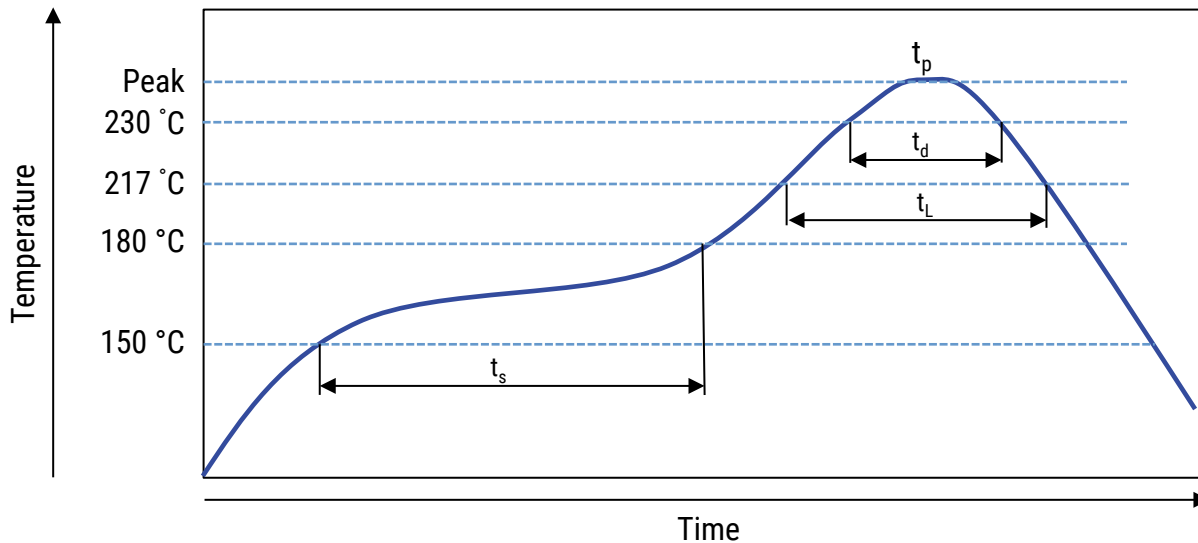

Lead Taping & Packaging

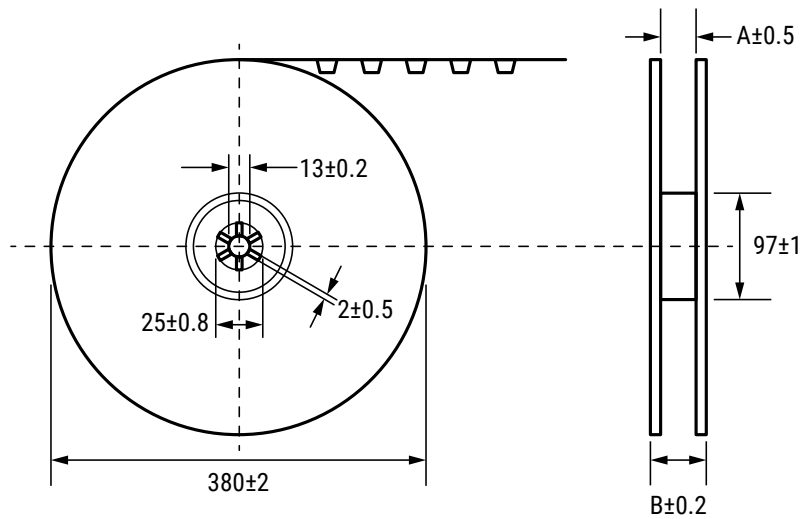

Size Code	Diameter (mm)	Length (mm)	Reel Quantity/SPQ	Box Quantity	Reel	
					A	B
					±0.5	±0.2
KE	8	6.7	1,000	6,000	26	30
KS	8	12.2	400	2,400	26	30
MS	10	12.2	400	2,400	26	30
MS (Anti-Vibration)	10	12.4	400	2,400	26	30

Taping for Automatic Insertion Machines

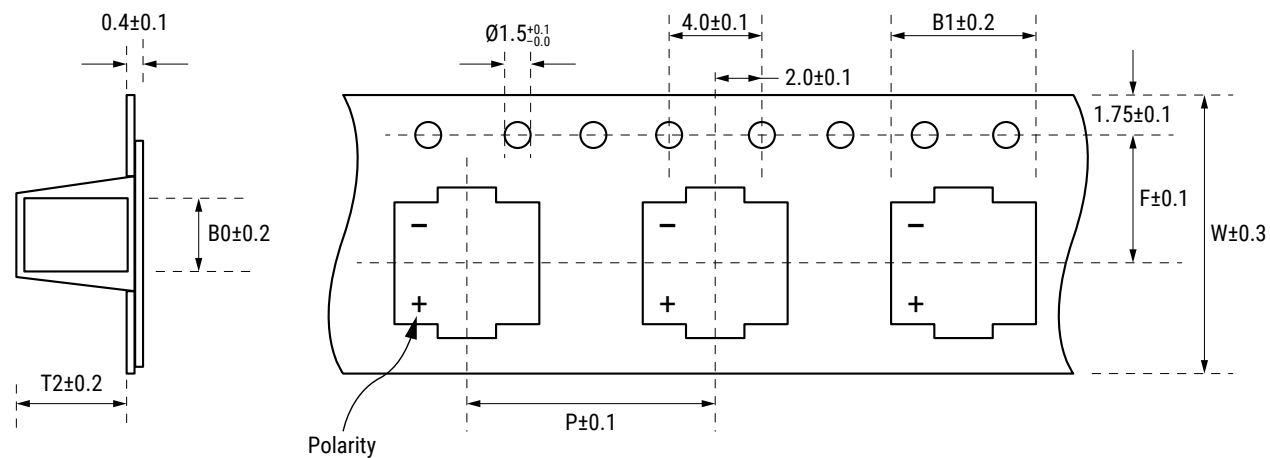

Size Code	Diameter	Length	W	P	F	B1	B0	T2
	(mm)	(mm)	±0.3	±0.1	±0.1	±0.2	±0.2	±0.2
KE	8.0	6.7	24.0	12.0	11.5	8.6	8.6	6.8
KS	8.0	12.2	24.0	16.0	11.5	8.6	8.6	12.5
MS	10.0	12.2	24.0	16.0	11.5	10.7	10.7	12.5
MS (Anti-Vibration)	10.0	12.4	24.0	16.0	11.5	11.2	10.7	12.7

Construction Data

The manufacturing process begins with the anode foil being electrochemically etched to increase the surface area and then 'formed' to produce the aluminum oxide layer. Both the anode and cathode foils are then interleaved with absorbent paper and wound into a cylinder. During the winding process, aluminum tabs are attached to each foil to provide the electrical contact.

The deck, complete with terminals, is attached to the tabs and then folded down to rest on top of the winding. The complete winding is impregnated with a conductive polymer electrolyte before being housed in a suitable container, usually an aluminum can, and sealed. Throughout the process, all materials inside the housing must be maintained at the highest purity and be compatible with the electrolyte.

Each capacitor is aged and tested before being packed. The purpose of aging is to repair any damage in the oxide layer and thus reduce the leakage current to a very low level. Aging is normally carried out at the rated temperature of the capacitor and is accomplished by applying voltage to the device while carefully controlling the supply current. The process may take several hours to complete. Damage to the oxide layer can occur due to variety of reasons:

- Slitting of the anode foil after forming
- Attaching the tabs to the anode foil
- Minor mechanical damage caused during winding

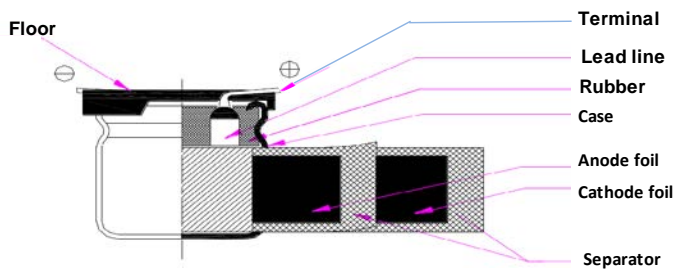
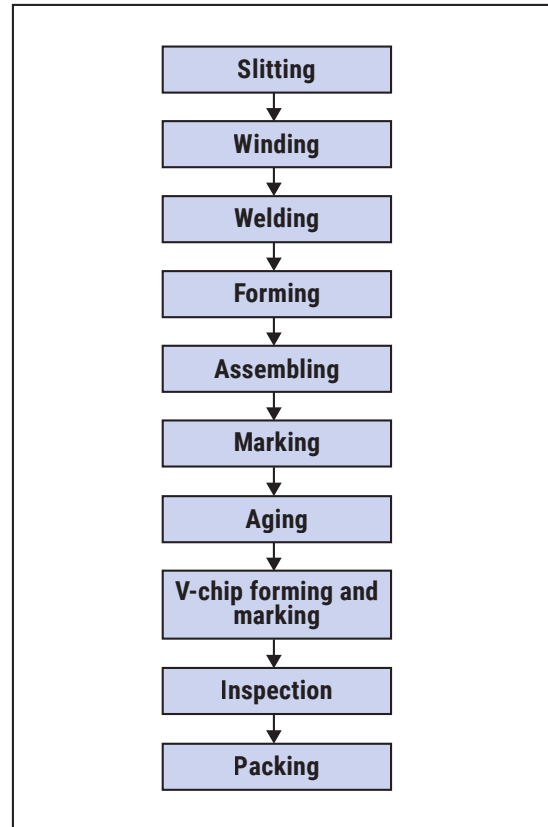

Product Safety

THESE NOTES SHOULD BE READ IN CONJUNCTION WITH THE PRODUCT DATA SHEET. FAILURE TO OBSERVE THE RATINGS AND THE INFORMATION ON THIS SHEET MAY RESULT IN A SAFETY HAZARD.

Warning

When potential lethal voltages e.g. 30 VAC (RMS) or 60 VDC are applied to the terminals of this product, the use of a hazard warning label is recommended.

1. Electrolyte

Conductive polymer aluminum solid electrolytic capacitors contain polymers (electrolytes) which can be hazardous.

1.1 Safety Precautions

In the event of gas venting, avoid contact and inhalation. Wash the affected area with hot water. Use rubber gloves to avoid skin contact. Any contact with the eyes should be liberally irrigated with water and medical advice sought.

2. Intrinsic Properties

2.1 Operating

DC capacitors are polar devices and will operate safely only if correctly connected. Reversing the connections will result in high leakage currents which could subsequently cause short circuit failure and possibly explosion and fire. Correctly polarized operation may result in the above failure modes if:

- The surge voltage is exceeded
- The ambient temperature is too high
- Excessive ripple currents are applied

2.2 Non-Operating

Excessive torque or soldering heat may affect the performance of the capacitor or damage the sealing. Electric shock may result if capacitors are not discharged.

3. Disposal

Aluminum electrolytic capacitors are consignable waste under the Special Waste Regulations 1996 (Statutory Instrument 1996 No 972), which complies with the EC Hazardous Waste Directive – Directive 91/689/EEC. The electrolyte should therefore be treated as a hazardous waste and advice should be sought from the local office of the Environmental Agency regarding its disposal.

Due to the construction of an aluminum electrolytic capacitors, high temperature incineration may cause the component to explode due to build-up of internal pressure. In addition, incineration may also cause the emission of noxious fumes. KEMET strongly recommends that if there are any doubts regarding the disposal of conductive polymer aluminum solid electrolytic capacitors, that advice be sought from the local regulating authority.

In addition, KEMET would like to request that users of aluminum electrolytic capacitors respect the needs of the environment and, wherever possible, recover as much of the materials as possible, i.e., aluminum.

Product Safety cont.

4. Unsafe Use

Most failures are of a passive nature and do not represent a safety hazard. A hazard may, however, arise if this failure causes a dangerous malfunction of the equipment in which the capacitor is employed. Circuits should be designed to fail safe under the normal modes of failure.

The usual failure mode is an increase in leakage current or short circuit. Other possible modes are decrease of capacitance, increase in dissipation factor (and impedance) or an open circuit. Capacitors should be used in a well-ventilated enclosure or cabinet.

5. Mounting

Care should be taken when mounting by clamp so that any safety vent in the can is not covered.

6. Fumigation

In many countries throughout the world it is now common practice to fumigate shipments of products in order to control insect infestation, particularly when wooden packaging is used. Currently, methyl bromide is widely used as a fumigant, which can penetrate cardboard packing and polymer bags and, therefore, come into direct contact with equipment or components contained within.

If aluminum electrolytic capacitors become exposed to methyl bromide, then corrosion may occur, depending upon the concentration and exposure time to the chemical.

This failure mode can affect all types of KEMET aluminum electrolytic capacitors. Methyl bromide can penetrate the seals of aluminum electrolytic capacitors and cause internal corrosion of the anode connection, resulting in the component becoming open circuit. The rate of corrosion will depend upon the level of exposure to methyl bromide as well as the subsequent operating conditions, such as voltage and temperature. It may take months or, in some cases, several years before the component becomes open circuit.

7. Dielectric Absorption

A phenomenon known as the dielectric absorption can cause aluminum electrolytic capacitors to recharge themselves. The phenomenon is well known but impossible to predict with any great accuracy, so potentially any electrolytic product could be affected. Thus, a capacitor that has been charged and then completely discharged, will appear to recharge itself if left open circuit; this will manifest itself as a small voltage across the terminals of the capacitor. Generally, the voltages seen are less than 20 VDC, however, higher voltages have on occasion been reported.

In order to avoid any problems caused by this voltage, KEMET recommends that capacitors be discharged before connecting to the terminals.

KEMET Electronics Corporation Sales Offices

For a complete list of our global sales offices, please visit www.kemet.com/sales.

Disclaimer

All product specifications, statements, information and data (collectively, the "Information") in this datasheet are subject to change. The customer is responsible for checking and verifying the extent to which the Information contained in this publication is applicable to an order at the time the order is placed. All Information given herein is believed to be accurate and reliable, but it is presented without guarantee, warranty, or responsibility of any kind, expressed or implied.

Statements of suitability for certain applications are based on KEMET Electronics Corporation's ("KEMET") knowledge of typical operating conditions for such applications, but are not intended to constitute – and KEMET specifically disclaims – any warranty concerning suitability for a specific customer application or use. The Information is intended for use only by customers who have the requisite experience and capability to determine the correct products for their application. Any technical advice inferred from this Information or otherwise provided by KEMET with reference to the use of KEMET's products is given gratis, and KEMET assumes no obligation or liability for the advice given or results obtained.

Although KEMET designs and manufactures its products to the most stringent quality and safety standards, given the current state of the art, isolated component failures may still occur. Accordingly, customer applications which require a high degree of reliability or safety should employ suitable designs or other safeguards (such as installation of protective circuitry or redundancies) in order to ensure that the failure of an electrical component does not result in a risk of personal injury or property damage.

Although all product-related warnings, cautions and notes must be observed, the customer should not assume that all safety measures are indicated or that other measures may not be required.

KEMET is a registered trademark of KEMET Electronics Corporation.